COMMUNICATION MANUAL
DIGITAL PID CONTROLLER

FY400

FY600

FY700

FY800

FY900

JULY, 2005

FY_COMM_EN_V1



TAIWAN INSTRUMENT & CONTROL CO., LTD

Contents

1	Set up of the controller.....	1
2	System Configuration	2
2.1	RS485 Communication System	2
2.2	RS232 Communication System	2
3	Wiring Connection.....	3
3.1	RS485 Communication Wiring.....	3
3.2	RS232 Communication Wiring.....	3
4	MODBUS RTU Protocol	4
4.1	Message Configuration	4
4.2	ID Number (Slave Address).....	4
4.3	Function Code	4
4.4	Data	4
4.5	Error Check CRC	4
4.6	Abnormal Code	5
4.7	Message example of RTU mode	5
4.7.1	Reading (Read PV from slave controller 1).....	5
4.7.2	Setting (Set SV = 10.0 to slave controller 1)	5
4.7.3	Setting (Set SV = 10.0 and OUTL=100.0 to slave controller 1)....	6
5	MODBUS ASCII Protocol.....	7
5.1	Message Configuration	7
5.2	ID Number(Slave Address).....	7
5.3	Function Code	7
5.4	Data	7
5.5	Error Check LRC	7
5.6	Abnormal Code	8
5.7	Message example of ASCII mode.....	8
5.7.1	Setting (Set SV = 10.0 to slave controller 1)	8
5.7.2	Setting (Set SV = 10.0 and OUTL=100.0 to slave controller 1)....	9
6	TAIE Protocol	10
6.1	Message Configuration	10
6.2	Command	10
6.3	ID Number	10
6.4	Register Address	10
6.5	Data	10
6.6	Check Sum	11
6.7	Message example of TAIE Protocol	11

6.7.1	Read (Read PV from slave controller 1).....	11
6.7.2	Modify (Modify SV = 10.0 to slave controller 1).....	11
6.7.3	Write (Write SV = 100.0 to slave controller 1)	11
7	Register Map.....	12

1 Set up of the controller

Press  +  key 3 seconds to configure parameters in Level 3

Character	Name , Functions and Setting range	Default
<i>P S L</i>	Protocol Selection <i>r t U</i> : MODBUS RTU Protocol <i>A S C I</i> : MODBUS ASCII Protocol <i>t A I E</i> : TAIE Protocol	<i>r t U</i>
<i>b i t S</i>	Communication Bits <i>O _ B 1</i> : Odd parity , Data bits = 8 , Stop Bit = 1 <i>O _ B 2</i> : Odd parity , Data bits = 8 , Stop Bit = 2 <i>E _ B 1</i> : Even parity , Data bits = 8 , Stop Bit = 1 <i>E _ B 2</i> : Even parity , Data bits = 8 , Stop Bit = 2	<i>O _ B 1</i>
<i>i d . n o</i>	ID Number Range : 0 ~ 255	<i>1</i>
<i>b A U d</i>	Communication Baud rate <i>2 4</i> : 2400 bps <i>4 8</i> : 4800 bps <i>9 6</i> : 9600 bps <i>1 9 2</i> : 19200 bps <i>3 8 4</i> : 38400 bps	<i>3 8 4</i>

- When parameter *b i t S* or *b A U d* was changed, always turn on the power again. Otherwise, no communication is performed by using the changed value.

2 System Configuration

2.1 RS485 Communication System

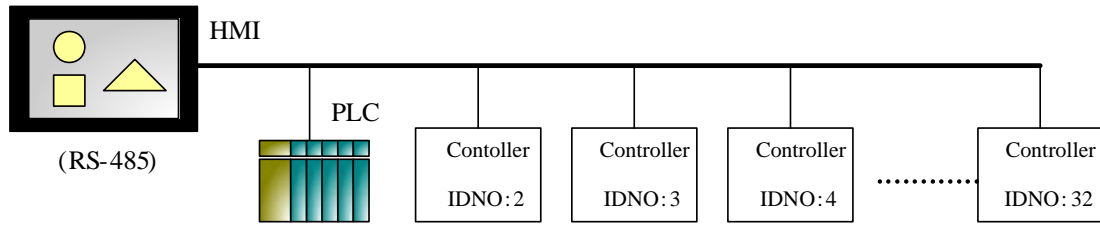

Figure: 2.1-1

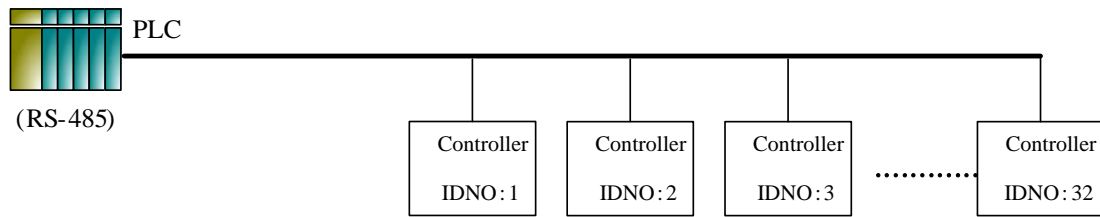

Figure: 2.1-2

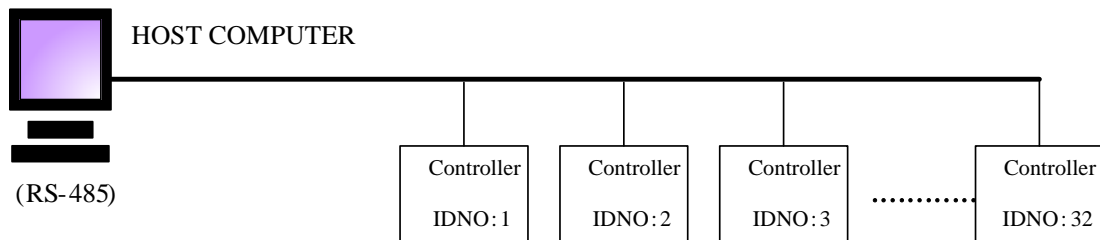

Figure: 2.1-3

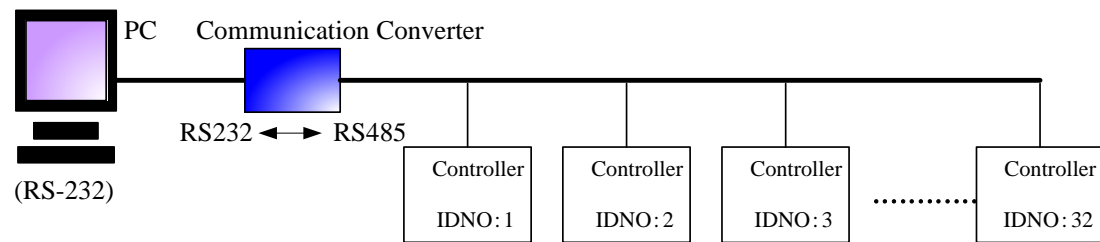

Figure: 2.1-4

2.2 RS232 Communication System

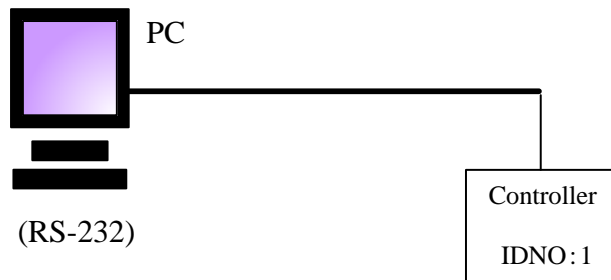

Figure: 2.2-1

3 Wiring Connection

3.1 RS485 Communication Wiring

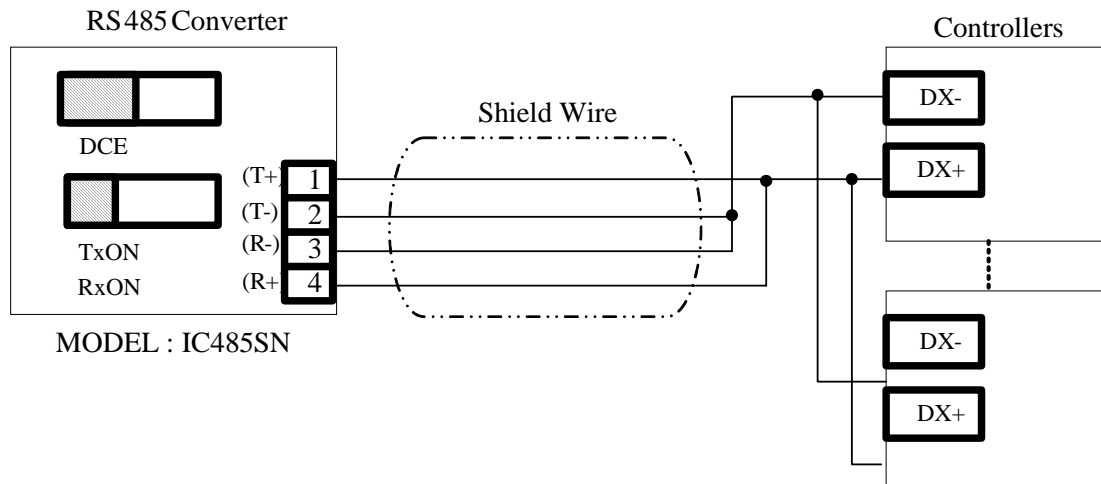

Figure: 3.1-1

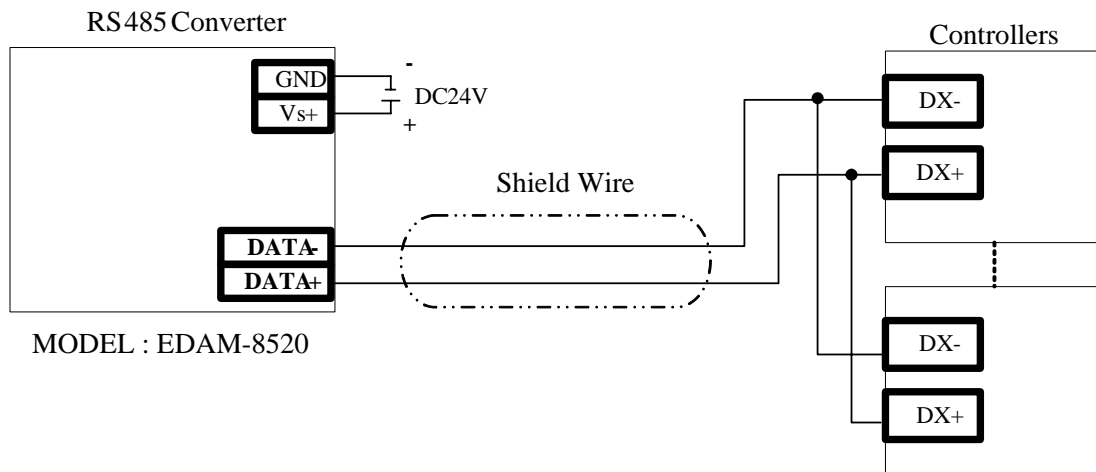
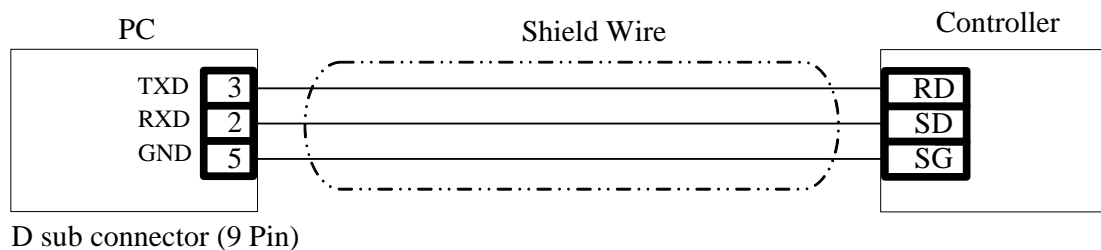

Figure: 3.1-2

- Note:
1. The length of shield wire should be less than 1200M.
 2. Controllers in RS485 parallel connection should be less than 32 units

3.2 RS232 Communication Wiring



- Note:
1. The length of shield wire should be less than 12M.
 2. There is only 1 unit of controller available in RS232 communication..

4 MODBUS RTU Protocol

4.1 Message Configuration

ID Number 1 Byte	Function Code 1 Byte	Data N Byte	CRC 2 Byte
---------------------	-------------------------	----------------	---------------

4.2 ID Number (Slave Address)

Range: 1~255.

Master instrument identifies slave controllers by the ID Number of the requested message. ID Number should be configuring in individual slave controller by setting parameter “IDNO” in operation LEVEL 3.

4.3 Function Code

Function Code	Contents
03 (03H)	Reading multiple registers value from slave controller (Max register count : 8)
06 (06H)	Setting 1 register value to slave controller
16 (10H)	Setting multiple registers value to slave controller. (Max register count : 8)

4.4 Data

Data depends on function code.

Request message from Master instrument is include “register address”, “data count” and “setting data”.

Response data from Slave controller is include “byte count”, “data” and “abnormal code”.

4.5 Error Check CRC

CRC16 generation polynomial: $X^{16} + X^{15} + X^2 + X^1$

CRC generation step is as below:

- ①. CRC is initialized as FFFFH
- ②. Calculate XOR with 1st data and the low byte of CRC. This is assumed as Y(16bit).
- ③. Shift Y one bit to the right. This assumed as Y.
- ④. If a carry is generated at step 3, then calculate XOR with Y and “A001H”, else jump to step 5.
- ⑤. Repeat step 3 and 4, until Y is shifting right 8 times.
- ⑥. Calculate XOR with next data and the low byte of Y. This is assumed as Y.
- ⑦. Repeat step 3 ~5.

- ⑧. Repeat step 3~5, until last data is processed.
- ⑨. Swap the low byte and high byte of Y.
- ⑩. CRC=Y

4.6 Abnormal Code

Abnormal Code	Contents
01 (01H)	Illegal function code (Non-existent function code)
02 (02H)	Illegal register address (Register address is out of range)
03 (03H)	Illegal data value (Data value is out of setting range)

4.7 Message example of RTU mode

4.7.1 Reading (Read PV from slave controller 1)

Request message from master instrument:

ID Number	Function Code	Register Address	Data Count	CRC
(01H)	(03H)	(008AH)	(0001H)	(A5E0H)

Response data from slave controller in normal status (Assumed PV=100.0)

ID Number	Function Code	Byte Count	Data	CRC
(01H)	(03H)	(02H)	(03E8H)	(B8FAH)

Response from slave controller in abnormal status (Assumed as illegal data value)

ID Number	Function Code	Error Code	CRC
(01H)	(83H)	(03H)	(0131H)

1 is set to the MSB of function code in abnormal status (83H).

The abnormal code (03H) is returned as contents of error.

4.7.2 Setting (Set SV = 10.0 to slave controller 1)

Request message from master instrument:

ID Number	Function Code	Register Address	Setting Data	CRC
(01H)	(06H)	(0000H)	(0064H)	(8821H)

Response message from slave controller in normal status (When SV = 10.0)

ID Number	Function Code	Register Address	Setting Data	CRC
(01H)	(06H)	(0000H)	(0064H)	(8821H)

Response from slave controller in abnormal status (Assumed as illegal data value)

ID Number (01H)	Function Code (86H)	Error Code (03H)	CRC (0261H)
--------------------	------------------------	---------------------	----------------

1 is set to the MSB of function code in abnormal status (86H).

The abnormal code (03H) is returned as contents of error.

4.7.3 Setting (Set SV = 10.0 and OUTL=100.0 to slave controller 1)

Request message from master instrument:

ID Number (01H)	Function Code (10H)	Register Address (0000H)	Data Count (0002H)	Byte Count (04H)	Data1 (0064H)	Data2 (03E8H)	CRC (B2CEH)
-----------------------	---------------------------	--------------------------------	--------------------------	------------------------	------------------	------------------	----------------

Response message from slave controller in normal status (When SV = 10.0 and OUTL=100.0)

ID Number (01H)	Function Code (10H)	Register Address (0000H)	Data Count (0002H)	CRC (41C8H)
-----------------------	---------------------------	--------------------------------	--------------------------	----------------

Response from slave controller in abnormal status (Assumed as illegal register address)

ID Number (01H)	Function Code (90H)	Error Code (02H)	CRC (C001H)
--------------------	------------------------	---------------------	----------------

1 is set to the MSB of function code in abnormal status (90H).

The abnormal code (02H) is returned as contents of error.

5 MODBUS ASCII Protocol

5.1 Message Configuration

Header (:)	ID Number	(Function Code)	Data	LRC	Delimiter (CR+LF)
1 Byte	2 Byte	2 Byte	2N Byte	2 Byte	2 Byte

5.2 ID Number(Slave Address)

Range: 1~255

Master instrument identifies slave controllers by the ID Number of the requested message. ID Number should be configuring in individual slave controller by setting parameter "IDNO" in operation LEVEL 3.

5.3 Function Code

Function Code	Contents
03 (30H 33H)	Reading multiple registers value from slave controller (Max register count : 8)
06 (30H 36H)	Setting 1 register value to slave controller
16 (31H 30H)	Setting multiple registers value to slave controller. (Max register count : 8)

5.4 Data

Data depends on function code.

Request message from Master instrument is include "register address", "data count" and "setting data".

Response data from Slave controller is include "byte count", "data" and "abnormal code".

5.5 Error Check LRC

LRC generation step is as below:

- ①. Convert all the messages to RTU mode (HEX code) ◦
- ②. Add all the values from "ID Number" to the end of "Data". This is assumed as Y(8Bit).
- ③. Calculate 2's complement with Y.
- ④. Convert Y to ASCII characters (16 bit)
- ⑤. LRC=Y

5.6 Abnormal Code

Abnormal Code	Contents
01 (30H 31H)	Illegal function code (Non-existent function code)
02 (30H 32H)	Illegal register address (Register address is out of range)
03 (30H 33H)	Illegal data value (Data value is out of setting range)

5.7 Message example of ASCII mode

● Reading (Read PV from slave controller 1)

Request message from master instrument:

Header	ID Number	Function Code	Register Address	Data Count	LRC	Delimiter
(3AH)	(30H 31H)	(30H 33H)	(30H 30H 38H 41H)	(30H 30H 30H 31H)	(37H31H)	(0DH 0AH)

Response data from slave controller in normal status (Assumed PV=100.0)

Header	ID Number	Function Code	Byte Count	Data	LRC	Delimiter
(3AH)	(30H 31H)	(30H 33H)	(30H32H)	(30H 33H 45H 38H)	(30H 46H)	(0DH 0AH)

Response from slave controller in abnormal status (Assumed as illegal data value)

Header	ID Number	Function Code	Error Code	LRC	Delimiter
(3AH)	(30H 31H)	(38H 33H)	(30H 33H)	(37H 39H)	(0DH 0AH)

5.7.1 Setting (Set SV = 10.0 to slave controller 1)

Request message from master instrument:

Header	ID Number	Function Code	Register Address	Data	LRC	Delimiter
(3AH)	(30H 31H)	(30H 36H)	(30H 30H 30H 30H)	(30H 30H 36H 34H)	(39H35H)	(0DH 0AH)

Response message from slave controller in normal status (When SV = 10.0)

Header	ID Number	Function Code	Register Address	Data	LRC	Delimiter
(3AH)	(30H 31H)	(30H 36H)	(30H 30H 30H 30H)	(30H 30H 36H 34H)	(39H35H)	(0DH 0AH)

Response from slave controller in abnormal status (Assumed as illegal data value)

Header	ID Number	Function Code	Error Code	LRC	Delimiter
(3AH)	(30H 31H)	(38H 36H)	(30H 33H)	(37H 36H)	(0DH 0AH)

1 is set to the MSB of function code in abnormal status (86H).

The abnormal code (03H) is returned as contents of error.

5.7.2 Setting (Set SV = 10.0 and OUTL=100.0 to slave controller 1)

Request message from master instrument:

Header	ID Number	Function Code	Register Address	Data Count	BYTE Count	Data1
(3AH)	(30H 31H)	(31H 30H)	(30H 30H 30H 30H)	(30H 30H 30H 32H)	(30H 34H)	(30H 30H 36H 34H)

Data2	LRC	Delimiter
(30H 33H 45H 38H)	(39H 41H)	(0DH 0AH)

Response message from slave controller in normal status (When SV = 10.0 and OUTL=100.0)

Header	ID Number	Function Code	Register Address	Data Count	LRC	Delimiter
(3AH)	(30H 31H)	(31H 30H)	(30H 30H 30H 30H)	(30H 30H 30H 32H)	(45H 44H)	(0DH 0AH)

Response from slave controller in abnormal status (Assumed as illegal register address)

Header	ID Number	Function Code	Error Code	LRC	Delimiter
(3AH)	(30H 31H)	(39H 30H)	(30H 32H)	(36H 44H)	(0DH 0AH)

6 TAIE Protocol

6.1 Message Configuration

Master → Slave (7 Bytes):

Command	ID Number	Register Address	Data	Check Sum
1 Byte	1 Byte	2 Byte	2 Byte	1 Byte

Master ← Slave (8 Bytes)

Header (07H)	Command (4DH)	ID Number	Register Address	Data	Check Sum
1 Byte	1 Byte	1 Byte	2 Byte	2 Byte	1 Byte

6.2 Command

Command	Contents
R (52H)	Reading 1 register value from slave controller
M (4DH)	Modify 1 register value in RAM. (Data are not maintained after power off)
W (57H)	Write 1 register value in both RAM and EEPROM. (Data are maintained after power off)

6.3 ID Number

Range: 1~255.

Master instrument identifies slave controllers by the ID Number of the requested message. ID Number should be configuring in individual slave controller by setting parameter “IDNO” in operation LEVEL 3.

6.4 Register Address

Register Address is including register address High byte and Low byte.

Totally, there are 2 bytes.

For detail, please check with Register Map(Page:12)

6.5 Data

Data is including setting data High byte and Low byte.

Totally, there are 2 bytes.

6.6 Check Sum

Add all the values from “Command” to the end of “Data”.

The result is Check Sum (1 byte).

EX : 52H + 01H + 00H + 8AH + 00H + 00H = DDH

6.7 Message example of TAIE Protocol

6.7.1 Read (Read PV from slave controller 1)

Request message from master instrument:

Command	ID Number	Register Address	Data	Check Sum
(52H)	(01H)	(008AH)	(0000H)	(DDH)

Response data from slave controller (Assumed PV=100.0)

Header	Command	ID Number	Register Address	Data	Check Sum
(07H)	(4DH)	(01H)	(008AH)	(03E8H)	(C3H)

6.7.2 Modify (Modify SV = 10.0 to slave controller 1)

Request message from master instrument:

Command	ID Number	Register Address	Data	Check Sum
(4DH)	(01H)	(0000H)	(0064H)	(B2H)

6.7.3 Write (Write SV = 100.0 to slave controller 1)

Request message from master instrument:

Command	ID Number	Register Address	Data	Check Sum
(57H)	(01H)	(0000H)	(03E8H)	(43H)

7 Register Map

Parameters	Register Address		MODBUS	Setting Range
	HEX	DECIMAL	Function Code	
SV Set Point	0000	000	03/06/10H	
OUTL Output Limit	0001	001	03/06/10H	0 ~ 1000
AT Auto Tuning	0002	002	03/06/10H	0000H=NO 0001H=YES
AL1 Alarm 1 set value	0003	003	03/06/10H	
AL2 Alarm 2 set value	0004	004	03/06/10H	
AL3 Alarm 3 set value	0005	005	03/06/10H	
PTN Program Pattern	0006	006	03/06/10H	0 ~ 2
SEG Program Segment Display	0007H	007	03H	
TIMR Program Countdown Display	0008	008	03H	
SV_1 Set Point of Seg.1 (Pattern 1)	0009	009	03/06/10H	
TM_1 Run Time of Seg.1 (Pattern 1)	000A	010	03/06/10H	
OUT1 Output Limit of Seg.1 (Pattern 1)	000B	011	03/06/10H	
SV_2 Set Point of Seg.2 (Pattern 1)	000C	012	03/06/10H	

Parameters	Register Address		MODBUS	Setting Range
	HEX	DECIMAL	Function Code	
TM_2 Run Time of Seg.2 (Pattern 1)	000D	013	03/06/10H	
OUT2 Output Limit of Seg.2 (Pattern 1)	000E	014	03/06/10H	
SV_3 Set Point of Seg.3 (Pattern 1)	000F	015	03/06/10H	
TM_3 Run Time of Seg.3 (Pattern 1)	0010	016	03/06/10H	
OUT3 Output Limit of Seg.3 (Pattern 1)	0011	017	03/06/10H	
SV_4 Set Point of Seg.4 (Pattern 1)	0012	018	03/06/10H	
TM_4 Run Time of Seg.4 (Pattern 1)	0013	019	03/06/10H	
OUT4 Output Limit of Seg.4 (Pattern 1)	0014	020	03/06/10H	
SV_5 Set Point of Seg.5 (Pattern 1)	0015	021	03/06/10H	
TM_5 Run Time of Seg.5 (Pattern 1)	0016	022	03/06/10H	
OUT5 Output Limit of Seg.5 (Pattern 1)	0017	023	03/06/10H	
SV_6 Set Point of Seg.6 (Pattern 1)	0018	024	03/06/10H	

Parameters	Register Address		MODBUS	Setting Range
	HEX	DECIMAL	Function Code	
TM_6 Run Time of Seg.6 (Pattern 1)	0019	025	03/06/10H	
OUT6 Output Limit of Seg.6 (Pattern 1)	001A	026	03/06/10H	
SV_7 Set Point of Seg.7 (Pattern 1)	001B	027	03/06/10H	
TM_7 Run Time of Seg.7 (Pattern 1)	001C	028	03/06/10H	
OUT7 Output Limit of Seg.7 (Pattern 1)	001D	029	03/06/10H	
SV_8 Set Point of Seg.8 (Pattern 1)	001E	030	03/06/10H	
TM_8 Run Time of Seg.8 (Pattern 1)	001F	031	03/06/10H	
OUT8 Output Limit of Seg.8 (Pattern 1)	0020	032	03/06/10H	
SV_12 Set Point of Seg.1 (Pattern 2)	0021	033	03/06/10H	
TM_12 Run Time of Seg.1 (Pattern 2)	0022	034	03/06/10H	
OUT12 Output Limit of Seg.1 (Pattern 2)	0023	035	03/06/10H	
SV_22 Set Point of Seg.2 (Pattern 2)	0024	036	03/06/10H	

Parameters	Register Address		MODBUS	Setting Range
	HEX	DECIMAL	Function Code	
TM_22 Run Time of Seg.2 (Pattern 2)	0025	037	03/06/10H	
OUT22 Output Limit of Seg.2 (Pattern 2)	0026	038	03/06/10H	
SV_32 Set Point of Seg.3 (Pattern 2)	0027	039	03/06/10H	
TM_32 Run Time of Seg.3 (Pattern 2)	0028	040	03/06/10H	
OUT32 Output Limit of Seg.3 (Pattern 2)	0029	041	03/06/10H	
SV_42 Set Point of Seg.4 (Pattern 2)	002A	042	03/06/10H	
TM_42 Run Time of Seg.4 (Pattern 2)	002B	043	03/06/10H	
OUT42 Output Limit of Seg.4 (Pattern 2)	002C	044	03/06/10H	
SV_52 Set Point of Seg.5 (Pattern 2)	002D	045	03/06/10H	
TM_52 Run Time of Seg.5 (Pattern 2)	002E	046	03/06/10H	
OUT52 Output Limit of Seg.5 (Pattern 2)	002F	047	03/06/10H	
SV_62 Set Point of Seg.6 (Pattern 2)	0030	048	03/06/10H	

Parameters	Register Address		MODBUS	Setting Range
	HEX	DECIMAL	Function Code	
TM_62 Run Time of Seg.6 (Pattern 2)	0031	049	03/06/10H	
OUT62 Output Limit of Seg.6 (Pattern 2)	0032	050	03/06/10H	
SV_72 Set Point of Seg.7 (Pattern 2)	0033	051	03/06/10H	
TM_72 Run Time of Seg.7 (Pattern 2)	0034	052	03/06/10H	
OUT72 Output Limit of Seg.7 (Pattern 2)	0035	053	03/06/10H	
SV_82 Set Point of Seg.8 (Pattern 2)	0036	054	03/06/10H	
TM_82 Run Time of Seg.8 (Pattern 2)	0037	055	03/06/10H	
OUT82 Output Limit of Seg.8 (Pattern 2)	0038	056	03/06/10H	
P1 OUT1 Proportional Band	0039	057	03/06/10H	0~2000
I1 OUT1 Integral Time	003A	058	03/06/10H	0~3600
D1 OUT1 Derivative Time	003B	059	03/06/10H	0~900
DB1 Dead-band Time	003C	060	03/06/10H	0~1000
ATVL Auto Tuning Offset	003D	061	03/06/10H	
CYT1 OUT1 Cycle Time	003E	062	03/06/10H	0~150

Parameters	Register Address		MODBUS	Setting Range
	HEX	DECIMAL	Function Code	
HYS1 OUT1 Hysteresis	003F	063	03/06/10H	0~1000
P2 OUT2 Proportional Band	0040	064	03/06/10H	0~2000
I2 OUT2 Integral Time	0041	065	03/06/10H	0~3600
D2 OUT2 Derivative Time	0042	066	03/06/10H	0~900
CYT2 OUT2 Cycle Time	0043	067	03/06/10H	0~150
HYS2 OUT2 Hysteresis	0044	068	03/06/10H	0~1000
GAP1 OUT1 Control Gap	0045	069	03/06/10H	
GAP2 OUT2 Control Gap	0046	070	03/06/10H	
LCK Function Lock	0047	071	03/06/10H	0000H = 0000 1111H = 1111 0100H = 0100 0110H = 0110 0001H = 0001 0101H = 0101
INP1 Input Type Selection	0048	072	03/06/10H	0000H = K1 0001H = K2 0002H = K3 0003H = K4 0004H = K5 0005H = K6 0006H = J1 0007H = J2 0008H = J3 0009H = J4 000AH = J5 000BH = J6 000CH = R1 000DH = R2

Parameters	Register Address		MODBUS	Setting Range
	HEX	DECIMAL	Function Code	
INP1 Input Type Selection	0048	072	03/06/10H	000EH = S1 000FH = S2 0010H = B1 0011H = E1 0012H = E2 0013H = N1 0014H = N2 0015H = T1 0016H = T2 0017H = T3 0018H = W1 0019H = W2 001AH = PL1 001BH = PL2 001CH = U1 001DH = U2 001EH = U3 001FH = L1 0020H = L2 0021H = JP1 0022H = JP2 0023H = JP3 0024H = JP4 0025H = JP5 0026H = JP6 0027H = DP1 0028H = DP2 0029H = DP3 002AH = DP4 002BH = DP5 002CH = DP6 002DH = JP.1 002EH = JP.2 002FH = JP.3 0030H = JP.4 0031H = JP.5

Parameters	Register Address		MODBUS	Setting Range
	HEX	DECIMAL	Function Code	
INP1 Input Type Selection	0048	072	03/06/10H	0032H = JP.6 0033H = AN1 0034H = AN2 0035H = AN3 0036H = AN4 0037H = AN5
ANL1 Linear Input Zero Calibration	0049	073	03/06/10H	
ANH1 Linear Input Span Calibration	004A	074	03/06/10H	
DP Decimal Point Position	004B	075	03/06/10H	0000H = 0000 0001H = 000.0 0002H = 00.00 0003H = 0.000
LSPL Lower Set Point Limit	004C	076	03/06/10H	
USPL Upper Set Point Limit	004D	077	03/06/10H	
ANL2 Remote Input Zero Calibration	004E	078	03/06/10H	
ANH2 Linear Input Span Calibration	004F	079	03/06/10H	
ALD1 Alarm mode for AL1	0050	080	03/06/10H	0~19
ALT1 Alarm time for AL1	0051	081	03/06/10H	
ALD2 Alarm mode for AL2	0052	082	03/06/10H	0~19
ALT2 Alarm time for AL2	0053	083	03/06/10H	
ALD3 Alarm mode for AL3	0054	084	03/06/10H	0~19

Parameters	Register Address		MODBUS	Setting Range
	HEX	DECIMAL	Function Code	
ALT3 Alarm time for AL3	0055	085	03/06/10H	
HYSA Hysteresis for all Alarms	0056	086	03/06/10H	0000H=0000 0001H=0000 0010H=0010 0011H=0011 0100H=0100 0101H=0101 0110H=0110 0111H=0111 1000H=1000 1001H=1001 1010H=1010 1011H=1011 1100H=1100 1101H=1101 1110H=1110 1111H=1111
CLO1 OUT1 Lower Calibration	0057	087	03/06/10H	
CHO1 OUT1 Upper Calibration	0058	088	03/06/10H	
CLO2 OUT1 Lower Calibration	0059	089	03/06/10H	
CHO2 OUT1 Upper Calibration	005A	090	03/06/10H	
CLO3 TRS Lower Calibration	005B	091	03/06/10H	
CHO3 TRS Upper Calibration	005C	092	03/06/10H	
RUCY Full run time of motor valve	005D	093	03/06/10H	
WAIT Full run time of proportional motor valve	005E	094	03/06/10H	

Parameters	Register Address		MODBUS	Setting Range
	HEX	DECIMAL	Function Code	
SETA	005F	095	03/06/10H	
PSL Protocol Selection	0060	096	03H	0~2
BITS Communication Bits	0061	097	03H	0~3
IDNO ID Number	0062	098	03H	0~255
BAUD Baud rate	0063	099	03H	0~4
SVOS SV Compensation	0064	100	03/06/10H	
PVOS PV Compensation	0065	101	03/06/10H	
UNIT Unit of PV and SV	0066	102	03/06/10H	0000H=C 0001H=F 0002H=A
PVFT PV Filter	0067	103	03/06/10H	0 ~ 1000
CASC	0068	104	03/06/10H	
ODU Heating / Cooling selection	0069	105	03/06/10H	0000H=HEAT 0001H=COOL
OPAD Control Algorithm	006A	106	03/06/10H	0000H=PID 0001H=FUZZY
HZ Power Frequency	006B	107	03/06/10H	0000H=60HZ 0001H=50HZ
SET1 Hide/ Display parameter	006C	108	03/06/10H	0000H=0000 0001H=0000 0010H=0010 0011H=0011 0100H=0100 0101H=0101 0110H=0110 0111H=0111

Parameters	Register Address		MODBUS	Setting Range
	HEX	DECIMAL	Function Code	
SET1 Hide/ Display parameter	006C	108	03/06/10H	1000H=1000 1001H=1001 1010H=1010 1011H=1011 1100H=1100 1101H=1101 1110H=1110 1111H=1111
SET2 Hide/ Display parameter	006D	109	03/06/10H	Same with SET1
SET3 Hide/ Display parameter	006E	110	03/06/10H	Same with SET1
SET4 Hide/ Display parameter	006F	111	03/06/10H	Same with SET1
SET5 Hide/ Display parameter	0070	112	03/06/10H	Same with SET1
SET6 Hide/ Display parameter	0071	113	03/06/10H	Same with SET1
SET7 Hide/ Display parameter	0072	114	03/06/10H	Same with SET1
SET8 Hide/ Display parameter	0073	115	03/06/10H	Same with SET1
SET9 Hide/ Display parameter	0074	116	03/06/10H	Same with SET1
SET0 Hide/ Display parameter	0075	117	03/06/10H	Same with SET1
INP2 Hide/ Display parameter	0076	118	03/06/10H	0 ~ 2
OUTY Output mode selection	0077	119	03/06/10H	0 ~ 5

Parameters	Register Address		MODBUS	Setting Range
	HEX	DECIMAL	Function Code	
VER Firmware Version	0086	134	03H	104
OUT% Output percentage	0087	135	03H	0~1000
OBIT Controller Information Bit	0088	136	03H	<u>0000 0000 0000 0000</u> 2^{15} ~ 2^0 2^{15} : Message nnn2 2^{14} : Message UUU2 2^{13} : Message nnn1 2^{12} : Message UUU1 2^{11} : Message IN2E 2^{10} : Message CJCE 2^9 : Message ADCF 2^8 : Message IN1E 2^7 : MAN LED 2^6 : PRO LED 2^5 : AL3 LED 2^4 : AL2 LED 2^3 : AL1 LED 2^2 : AT LED 2^1 : OUT2 LED 2^0 : OUT1 LED
CV CT Current Value	0089	137	03H	0~999
PV Process Value	008A	138	03H	-1999~9999



TAIWAN INSTRUMENT & CONTROL CO., LTD
FY400/600/700/800/900 COMMUNICATION MANUAL

